

200mm Semi-Automatic Wafer Mounter

RAD-2500m/8

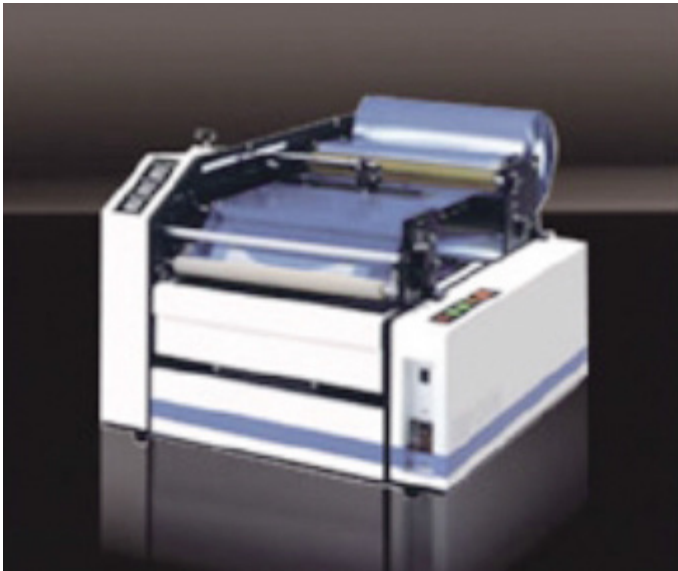

Outline

-Semi-automatic wafer mounter that mounts wafer onto the pre-cut dicing tape once the operator supplies the wafer and ring frame by hand.

Options

- Static Eliminator
- Top Cover
- Wafer Positioning Pins

Suitable Tapes

- Pre-cut dicing tape : Adwill D series, G series
- Dicing die bonding tape : Adwill LE Tape

External View

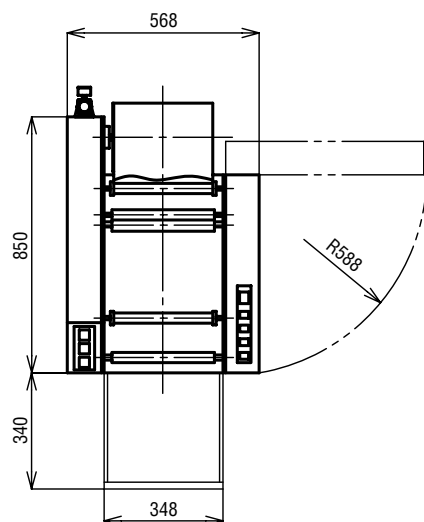

Top View

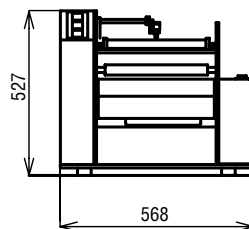

Front View

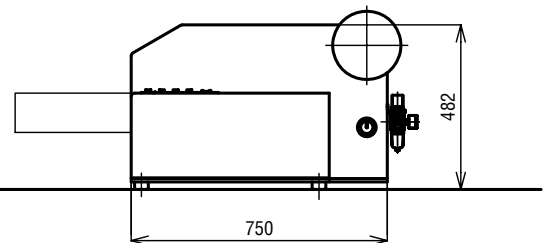

Right Side View

Unit:mm

Facility

Power Supply	Voltage	: AC100V (±10%)
	Frequency	: 50/60Hz
	Phase	: single phase
Air Supply	Power consumption	: 0.2kW
	Air pressure	: 0.5-0.8MPa
	Air consumption	: >150L/min (ANR)

Applicable Wafer Size

200mm
Additional compatibility with various wafer sizes and shapes are available as an option. Please feel free to inquire.

Size

Width : 568mm
Depth : 850mm
(with table fully advanced : Max.1,190mm)
Height : 527mm

Weight

90kg

Processing Capacity

18sec/wafer (excludes setting time)



LINTEC Corporation *Linking your dreams*

●Head Office:23-23 Honcho, Itabashi-ku, Tokyo 173-0001, Japan

Contact:Advanced Materials Operations 8th Fl., Bunkyo Garden Gate Tower, 1-1-1 Koishikawa, Bunkyo-ku, Tokyo 112-0002, Japan
TEL. +81-3-3868-7737 FAX. +81-3-3868-7726

<https://www.adwill-global.com/en>